

# Digital 8-frequency conversion active infrared detector Installation guide ABL-(D) series

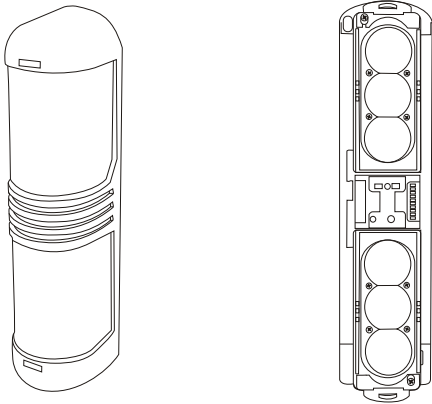

Designed by ZUDEN

## I. Model and parameters

Model	ABL-50(D)	ABL-100(D)	ABL-150(D)	ABL-200(D)	ABL-250(D)	ABL-300(D)
Distance	Outdoor 50m Indoor 150m	100m 300m	150m 450m	200m 600m	250m 750m	300m 900m
No.of beams	6 beams					
Detection mode	Single 3-beam or 6-beam blocked simultaneously					
Optical source	Infrared digital pulse beam					
Response time	40-250msec adjustment					
Alarm output	Relay contact output NO,NC contact rating DC30V 0.5A Max.					
Power supply voltage	DC 12-24V P≥15W					
Power supply	TX+RX≤60mA (when DC 15V, LED off, buzzer no alarm)					
Operation temperature&humidity	-25℃-55℃, 5%-95% RH (relative humidity)					
Dimensions	Refer to its diagram					
Tamper output	Contact output NC contact rating DC24V 0.5A Max					
Optical axis adjustment	H 180° (±90°); V20° (±10°)					
Viewfinder	Window mode					
Anti-dew,frost	Calcification housing (optional)					
Material	PC resin					
Net weight	2660g (TX+RX)					
Gross weight	3240g					

## II. Part name

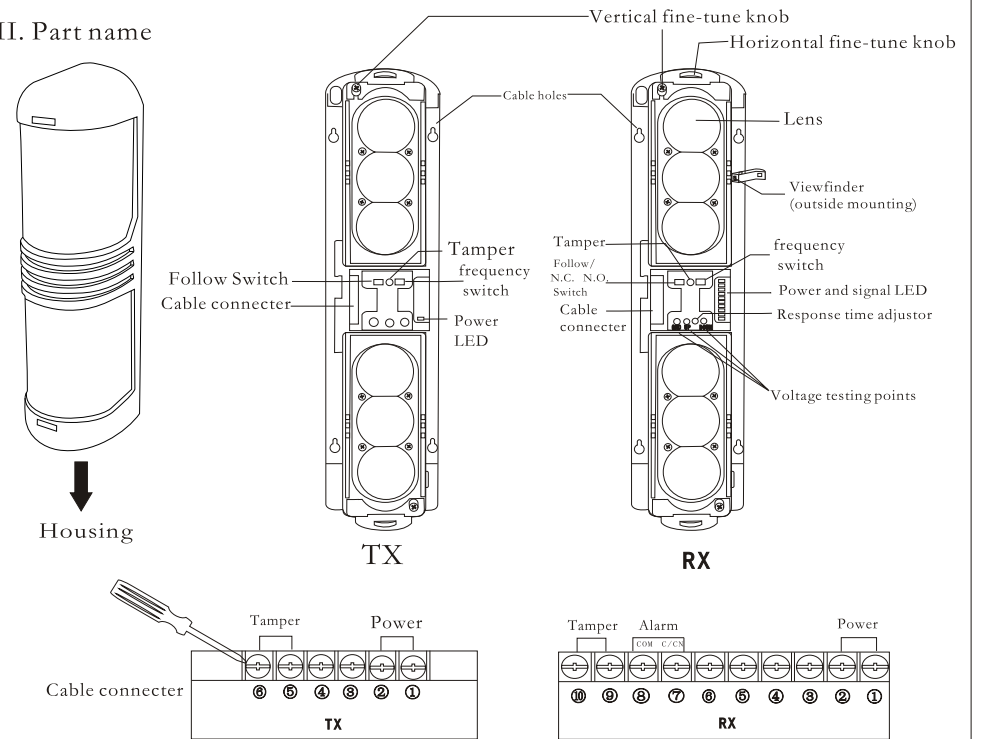

-1-

## III. Precautions for installation

### 3.1 Notes in installation

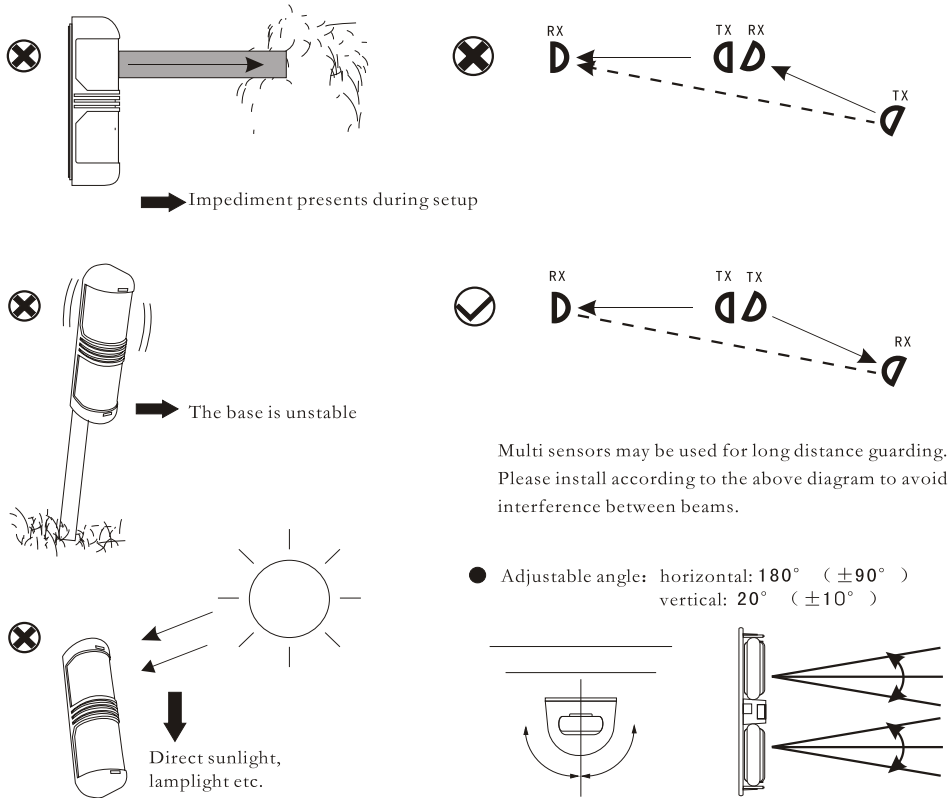

Multi sensors may be used for long distance guarding. Please install according to the above diagram to avoid interference between beams.

- Adjustable angle: horizontal: 180° (±90°)  
vertical: 20° (±10°)

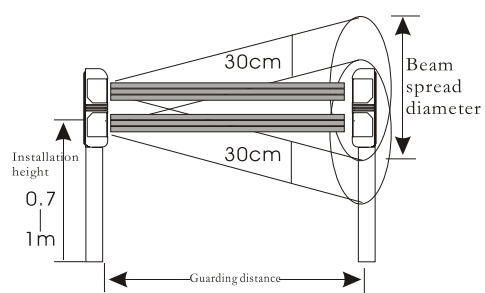

Model	Guarding distance	Beam spread diameter
ABL-50D	50m	0.8m
ABL-100D	100m	1.6m
ABL-150D	150m	2.4m
ABL-200D	200m	3.2m
ABL-250D	250m	4.0m
ABL-300D	300m	4.8m

-2-

### 3.2 Typical usage

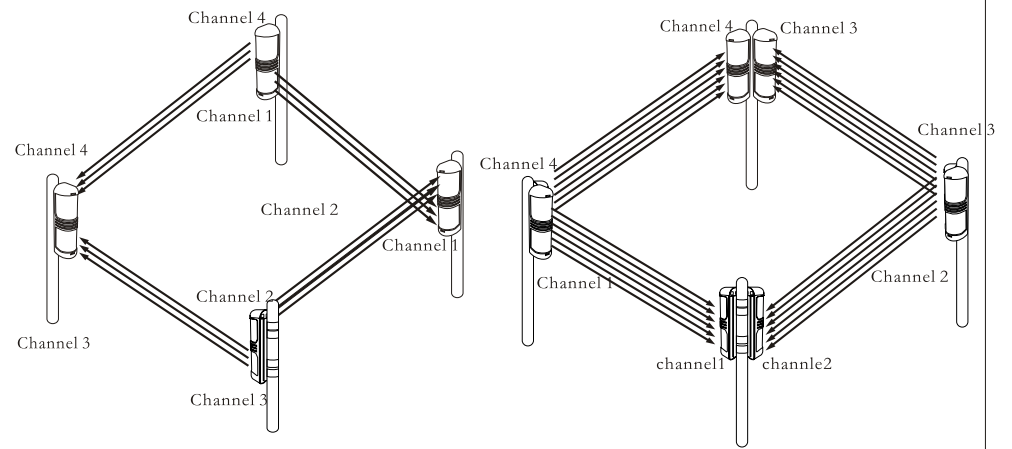

Usage 1: split installation (relay mode)  
Collocation: 2 pc TX, 2 pc RX

Usage 2: combination installation (reinforce mode)  
Collocation: 4 pc TX, 4 pc RX

### 3.3 Installation method

#### ★ Installation on the wall

1. Attach the paper stencil onto the location where the item is to be mounted, and drill the holes in the positions on its mark.

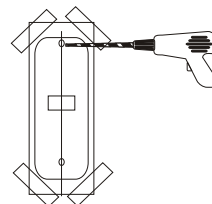

2. Remove the cover

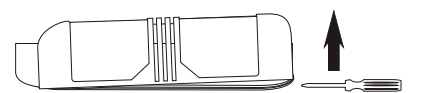

3. Put the cable through the hole for wiring.

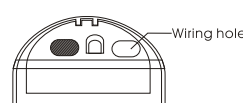

4. Fix the main body onto the wall.

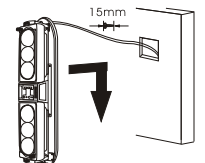

-3-

5. Connect the cable to the wire connector.

Wiring distance between TX and RX

Wire size	distance	voltage	DC13.8V	DC24V
0.5mm <sup>2</sup> (Φ 0.8)			200m	400m
0.75mm <sup>2</sup> (Φ 1.0)			300m	600m
1.25mm <sup>2</sup> (Φ 1.2)			600m	1200m
2.0mm <sup>2</sup> (Φ 1.6)			900m	1800m

6. Put on the cover back after adjusting the response time of the beam.

#### IV. Function description and setting

##### ① TX dip switch function

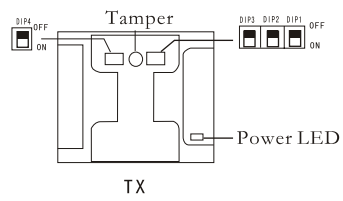

DIP4	0	1	2	3	4	5	6	7
1	0	1	0	1	0	1	0	1
2	0	0	1	1	0	0	1	1
3	0	0	0	0	1	1	1	1

NOTE: 0=OFF  
1=ON

If DIP4=ON, DIP1~3 are up,down beam frequency, up and down beam transmit at the same time, frequency is DIP1~3.

If DIP4=OFF, DIP1~3 are up beam frequency, down beam frequency is up frequency sequence plus 1. E.g.:up beam frequency is 1, so the down beam frequency should be 2.

(Note:up beam frequency is 7,down beam frequency should be 0)

Emphases: Must block down beam when justing up beam frequency, same opposition.

##### ② RX function discription

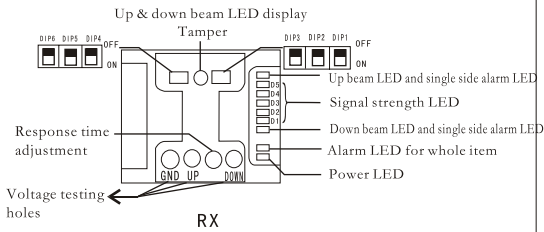

##### (1) Set Frequency

DIP4	0	1	2	3	4	5	6	7
1	0	1	0	1	0	1	0	1
2	0	0	1	1	0	0	1	1
3	0	0	0	0	1	1	1	1

NOTE: 0=OFF  
1=ON

If DIP4=ON, DIP1~3 are up,down beam frequency, up and down beam transmit at the same time, frequency is DIP1~3.

If DIP4=OFF, DIP1~3 are up beam frequency, down beam frequency is up frequency sequence plus 1. E.g.:up beam frequency is 1, so the down beam frequency should be 2.

(Note:up beam frequency is 7,down beam frequency should be 0)

##### (2) Set relay output to N.C. (Normal close)/N.O. (Normal open)

If DIP5=ON, alarm output is N.O.;Otherwise,alarm output is N.C. (Default: alarm output is N.C.)

##### (3) Set Buzzer switch

If DIP6=ON, the buzzer sounds shorts sound of "dee,dee"

In working state,D1~D5 display the signal strength received by up and down beams

##### ③ RX signal LED description

Signal strength instruction (LED5-LED1)	Grade
ON ON ON ON ON	10
ON ON ON ON FLASH	9
OFF ON ON ON ON	8
OFF ON ON ON FLASH	7
OFF ON ON ON ON	6
OFF OFF ON ON FLASH	5
OFF OFF OFF ON ON	4
OFF OFF OFF ON FLASH	3
OFF OFF OFF OFF ON	2
OFF OFF OFF OFF FLASH	1
OFF OFF OFF OFF OFF	0

#### V. Beam alignment

- Remove the cover and connect power.
- Put the viewfinder on the TX/RX,observe the collimation effect at a distance of 5cm from the viewfinder, adjust to let the image of opposite detector falls into the central part of the viewing hole.
- Set TX and RX up/down beam frequency, let up frequency same as down frequency separately.
- Block down beams of TX, adjust up beams,let them aim correctly, Choose up beams of RX, let signal strength up to grade 7,and up beam LED keep light.
- Adjust down beams refer to (4),signal LED strength instruction(grade 11),suggest set to above grade 7.
- Adjustment finished, put the cover back.

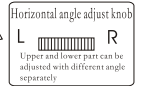
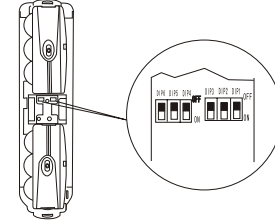
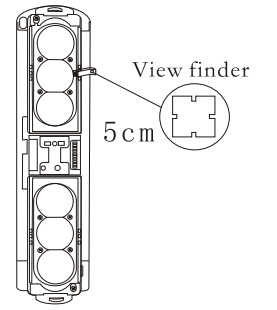

#### VI. Response time adjustment



Please see the diagram to adjust the response time of the RX. Usually, the time set shall be less than the time when intruder crosses the area.

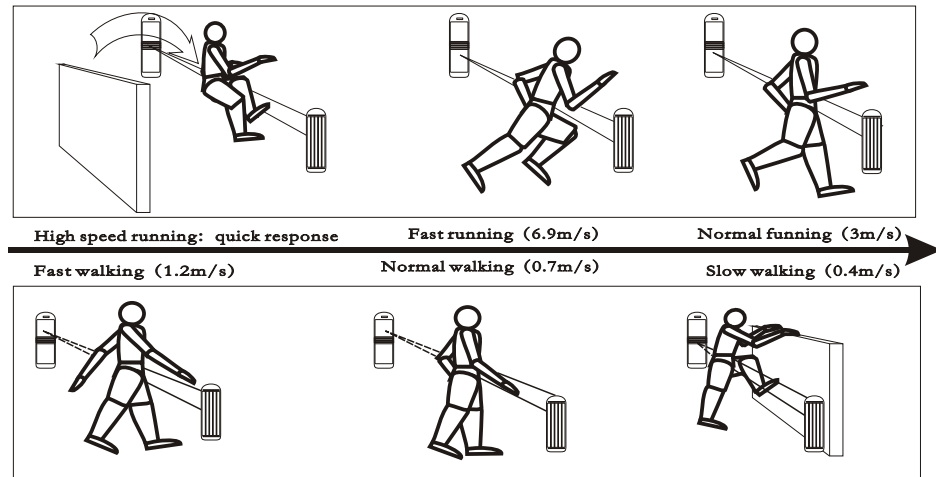

#### VII. Motion confirmation

	Up beam LED	Down beam LED	Signal strength LED	State
Up beam aiming (block down beam totally)	ON	—	Strong	Up beams are working well
	ON	—	Weak	Up beams are working well, but signal is weak
	FLASH	—	Strong	Signal strong, up beams alarm,maybe frequency is not correct.
	FLASH	—	Weak	Signal is weak,up beams alarm, aiming failed.
Down beam aiming (block up beam totally)	—	ON	Strong	Down beams are working well.
	—	ON	Weak	Down beams are working well,but signal is weak.
	—	FLASH	Strong	Signal is strong,down beams alarm, maybe frequency is not correct.
	—	FLASH	Weak	Signal is weak,down beams alarm,aiming failed.

Notice:when up or down beam displays "FLASH", it means their frequency is wrong, referring to handbook IV.

#### VIII. Installation brackets and dimensions

