

WIRED COMPATIBLE 2 BEAMS ACTIVE INFRARUSION DETECTORS

INSTALLATION GUIDE

ABT

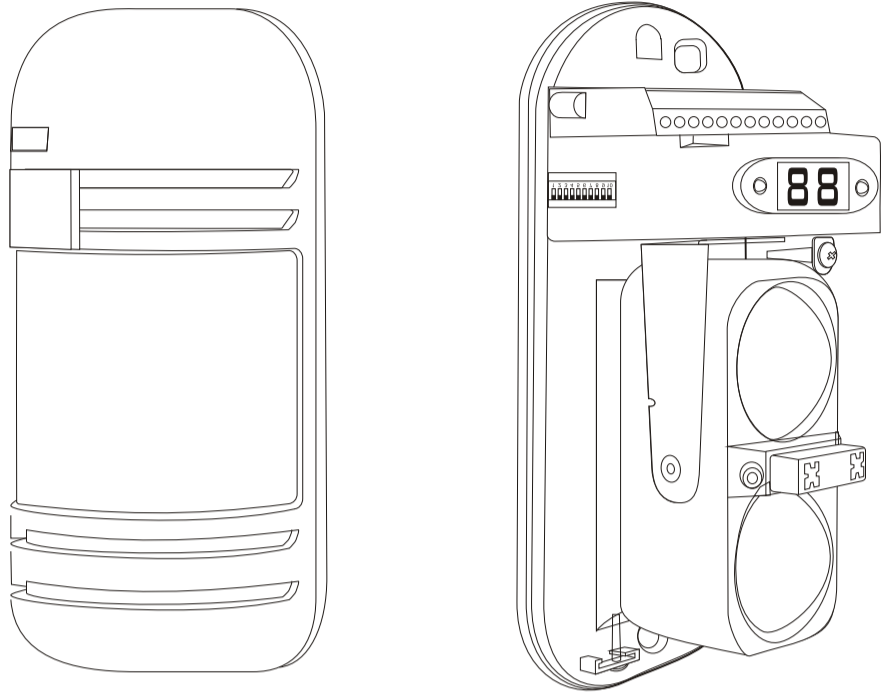

Designed by ZUDEN

I. Technical parameters:

Model	ABT-20B	ABT-30B	ABT-40B	ABT-60B	ABT-80B	ABT-100B
Alert distance	(Outdoor)	20m	30m	40m	60m	80m
	(Indoor)	60m	90m	120m	180m	240m
Number of beams	2 beams					
Detection mode	2 beams blocked simultaneous					
Optical source	Infrared digital pulse beam					
Response time	50-240ms (adjustable without degree)					
Power supply	DC13.8~24V 15W					
Alarm output	Relay contact output NO.NC contact rating AC/DC30V 30mAMax					
Trouble output	Relay contact output NC contact rating AC/DC30V 30mAMax					
Tamper output	Relay contact output NC contact rating DC24V 0.5Amax.					
Power consumption	In the bus mode 13.8V DC, ≤100mA					
Operation temperature&humidity	-25°C~55°C 5%-95%RH (relative humidity)					
Optical axis adjustment (H)	180° (±90°)					
Optical axis adjustment (V)	20° (±10°)					
Material	P C resin					
Net weight	430g (receiver+transmitter)					
Gross weight	790g					

II. Part name:

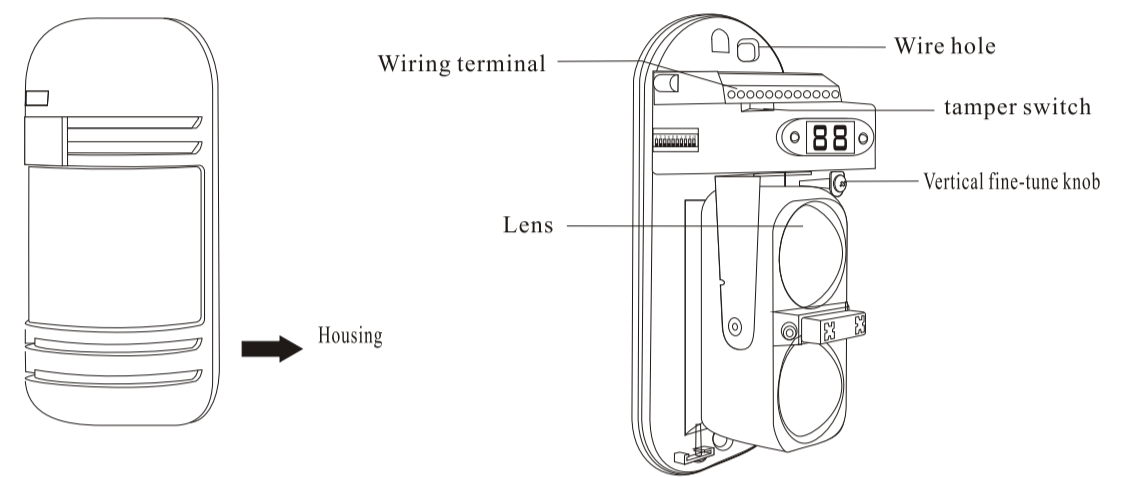

Feature:

- Under bus connection mode: The digital display of RX synchronize with the TX after the RX receive the signal from bus.
- Anti-fog function: when signal strength decrease slowly to 0.8V the detector will active anti-fog alarm (TBL output), when signal decrease to 0.4V, will active alarm. When signal get back to 1.2v cancel alarm.

1

III. Precautions for setting:

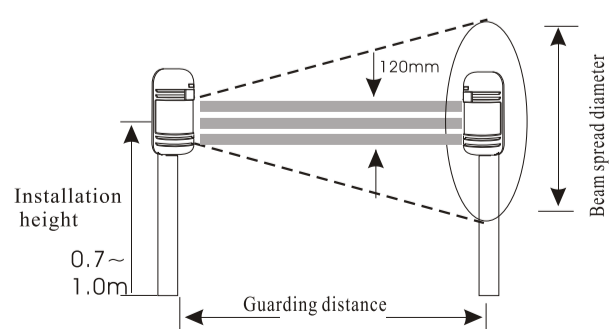
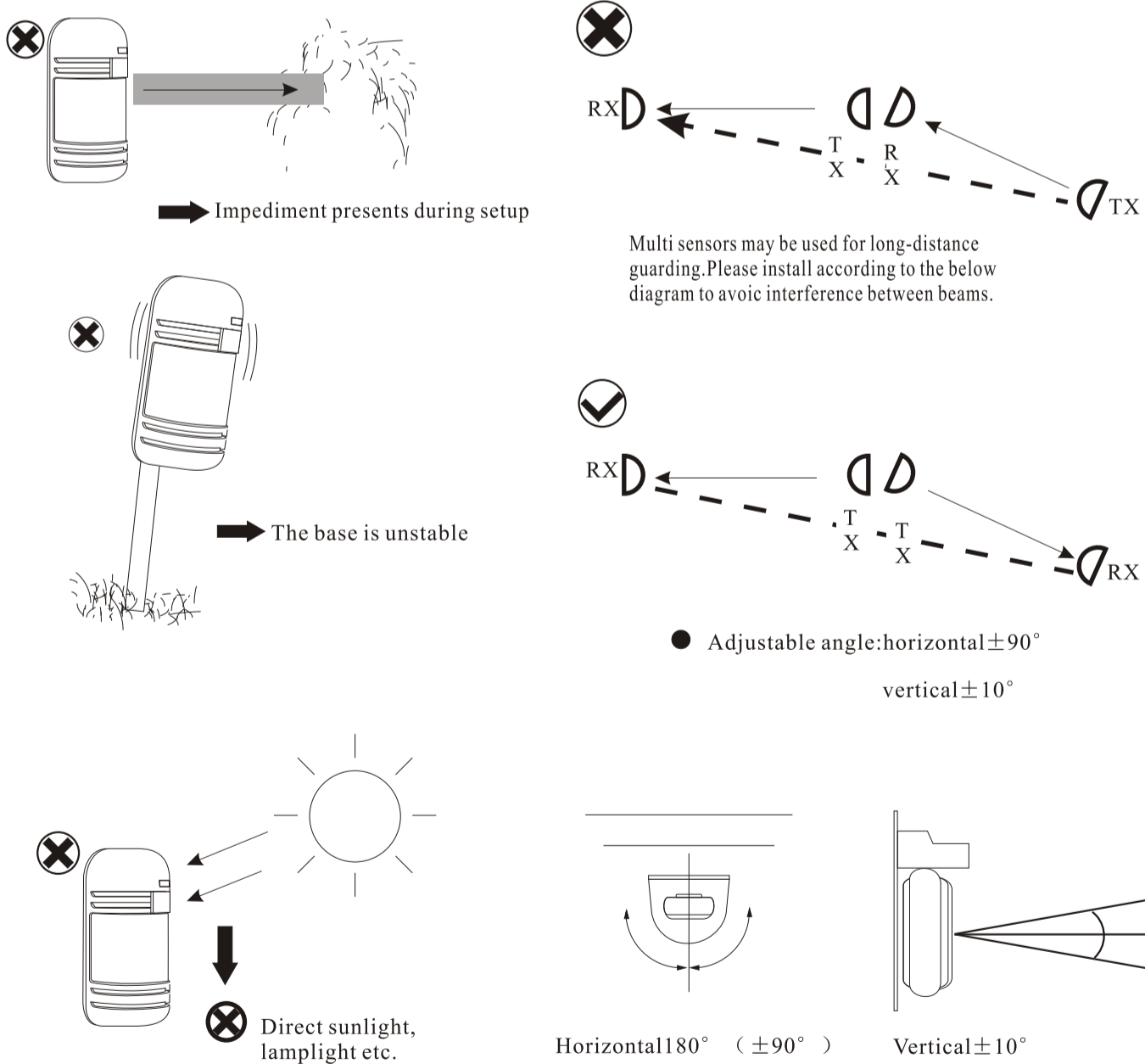

Style	Guarding distance	Beam spread diameter
ABT-20	20m	0.6m
ABT-30	30m	0.7m
ABT-40	40m	1.0m
ABT-60	60m	1.5m
ABT-80	80m	1.8m
ABT-100	100m	2.1m

2

IV. Setting procedure

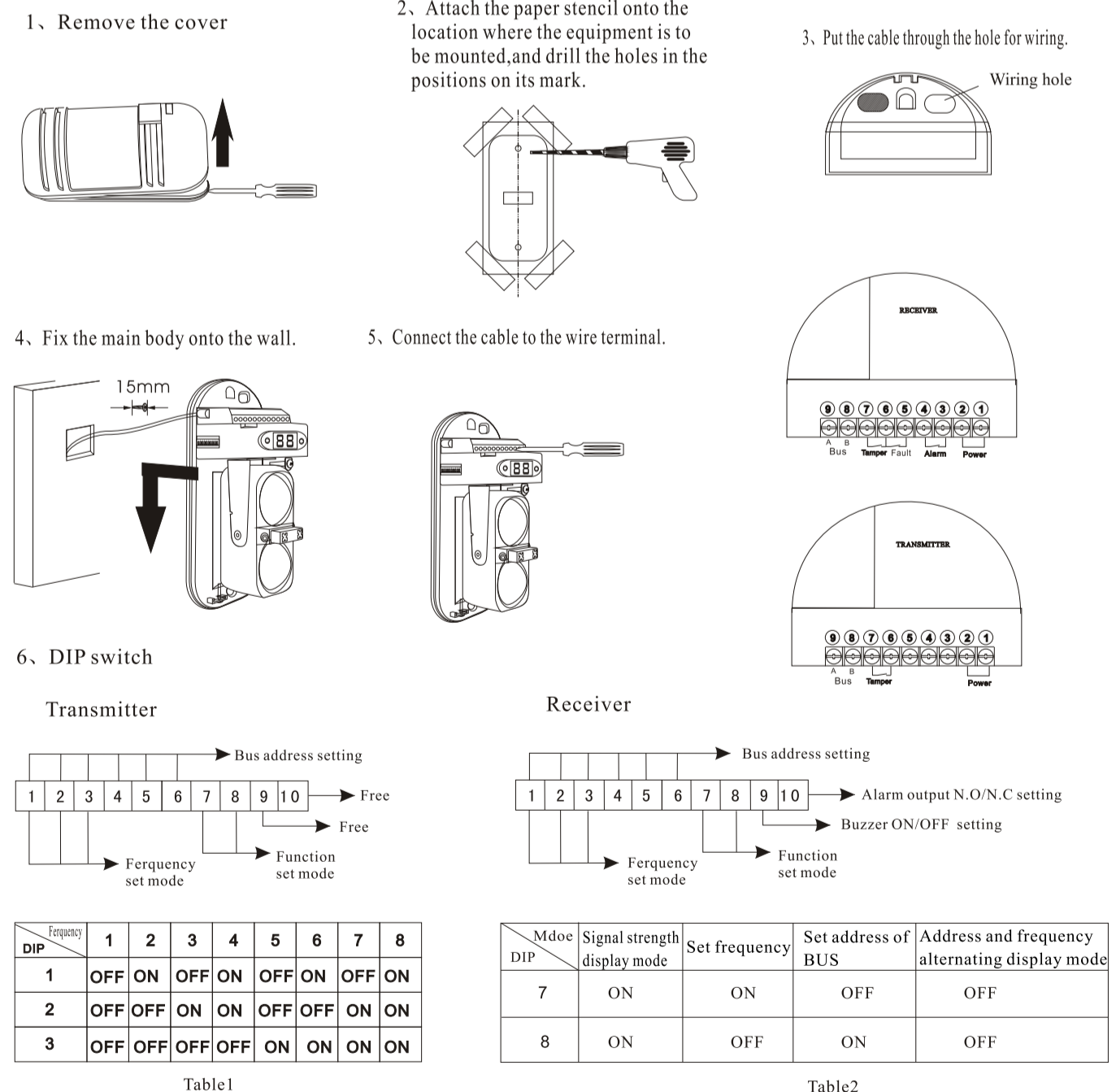

Function setting (table 2)

- Set frequency: set DIP 7 at ON, DIP 8 at OFF to enter the frequency setting mode, the digital display shows the frequency. Set frequency on DIP 1,2,3. see table 1.
 - Set address of BUS: set DIP 7 at off, DIP 8 at ON to enter address setting mode. The digital display shows the address number, set the address on DIP 1,2,3,4,5,6
 - Signal strength display mode: Set DIP 7 at ON, DIP 8 at ON to enter signal strength mode, the digital display shows the signal strength. The DIP 1,2,3,4,5,6 under this mode is free.
 - Address and frequency alternating display mode, set DIP 7 at OFF, DIP 8 at OFF to enter address and frequency alternating display mode. The DIP 1,2,3,4,5,6 under this mode is free.
- Frequency setting: First enter the frequency setting model (see table 2), Then set DIP 1,2,3 to set the detector's frequency. (see table 1)

3

Zone address setting (first enter the address setting mode, see table 2)
 Under address setting mode, Switch the DIP 1-6 to set the detector's zone address.
 First set the DIP at ON, the number of the one DIP which set ON plus the other one, then plus 1, the final result of number is the zone number. Example this is zone 18

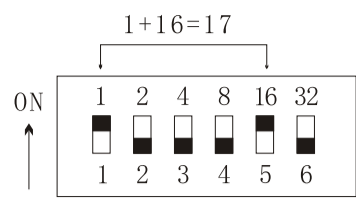

7. BUS Wiring :

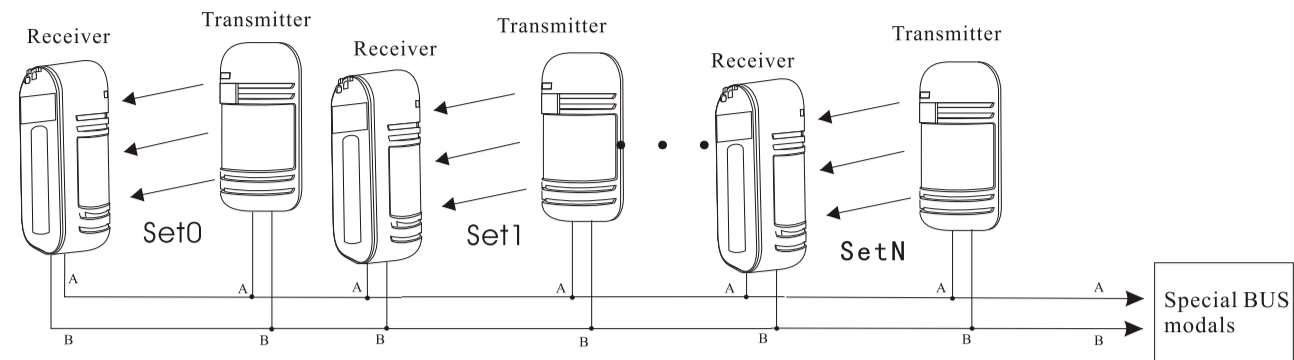

(NOTICE: MUST set BUS address from 0 to 31 in order, N ≤ 31)

8. Take back the cover after the adjustment of the response time.

● Installation of fixed bracket

1、Drill a hole on the bracket and extend out the cable from it.

2、Take off the cover.

3、Fasten the base-plate to the bracket.

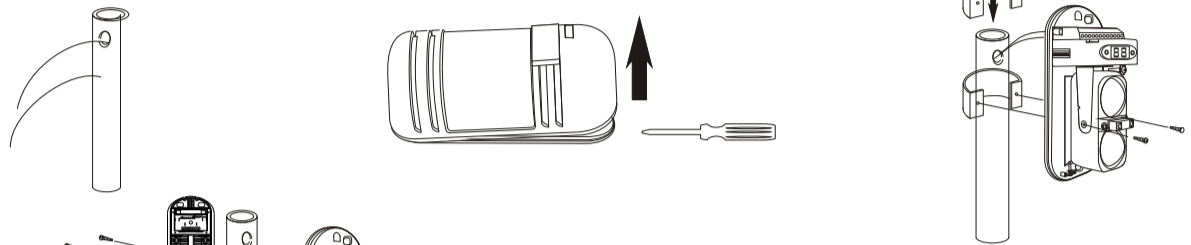

Wiring from power and bus

Wire	Distance	Voltage	DC13.8V	DC24V
0.5mm ² (Diameter Φ0.8)			300m	600m
0.75mm ² (Diameter Φ1.0)			400m	800m
1.25mm ² (Diameter Φ1.2)			700m	1400m
2.0mm ² (Diameter Φ1.6)			1000m	2000m

(Back-to-back installation guiding diagram.)

Note: please insert waterproof stopper into the hole of screw.

V. Beam alignment

1、Observe the collimation effect at a distance of 5cm from the viewfinder. Adjust the upper/lower angle regulation screw and horizontal adjustment wheel in order that the image of opposite detector falls into the central part of the viewing hole.

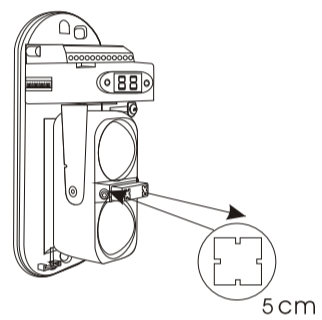

2. Vertical and horizontal adjust as below picture showed to get a best signal strength, if signal strength is less than 1.8, please adjust again to get a better signal strength.

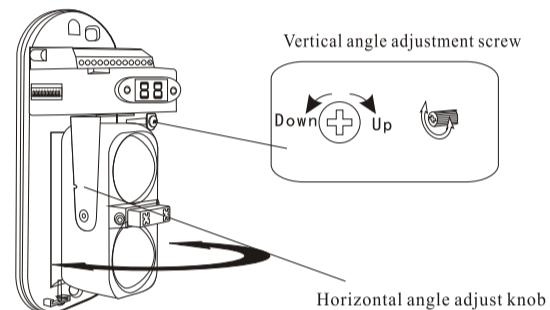

4

VI. Beam response time adjustment.

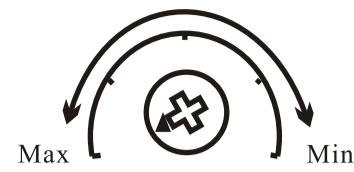

Please see the diagram to adjust the response time of the receiver. Usually, the time set shall be less than the time when the intruder crosses the guarding area. The MIN point is the shortest time.
 Time: 50-240m sec without degree

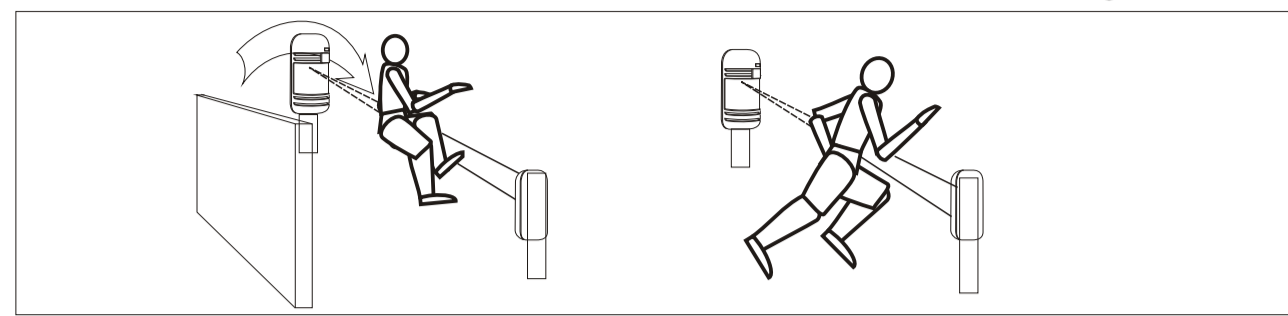

Fast walking: 1.2m/s Normal walking: 0.7m/s Slow walking: 0.4m/s

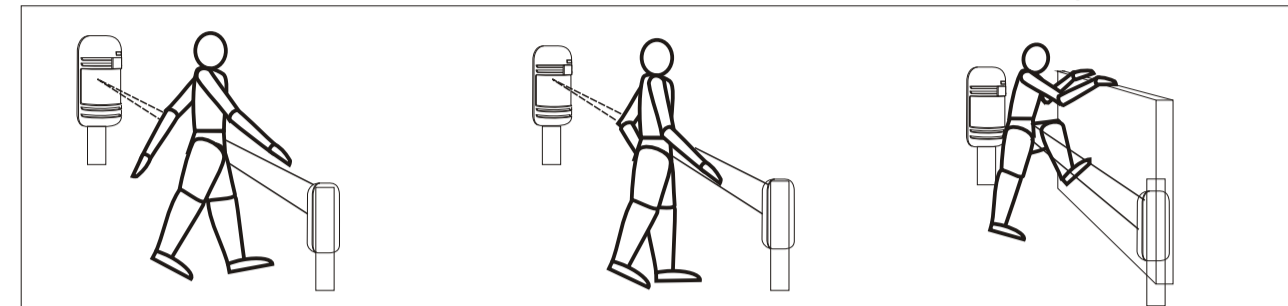

七、LED

After finish setting, please make walk test.

	Green	Red
TX flash when is bus signal	light on when there is no bus signal	always light on
RX flash when is bus signal	light on when there is no bus signal	light on when alarming, light off as normal status

IX. Dimension.

Physical appearance & dimension

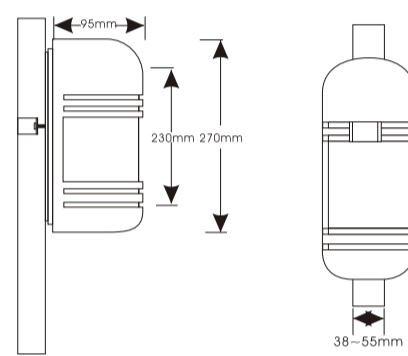

Brackets

L-shaped bracket
80×75mm

T-shaped bracket
T-100
100×120mm

T-200
200×120mm

I-shaped bracket

I-100
100mm
I-200
200mm



5